



# NST-2003

CE Approved:  
MD, EMC, LVD

## Category 2/3, EN 954-1

(Estimated category by 2-channel operation)

- 22,5 mm slim line emergency stop relay
- Transistor output for PLC monitoring
- New house types
- Choice between fixed and detachable terminals
- New voltage versions
- Same number of contacts as bigger and more space demanding relays

### Function:

Small and powerful emergency stop relay for monitoring of emergency stop and other safety arrangements, with the same applications as NST-3, but with transistor output for PLC monitoring and separate voltage output. Now also available in a 48-240 VAC version.

### Technical facilities regarding safety requirements:

- Forced contacts
- Doubling of output contacts
- Redundancy of emergency stop
- Manual / automatic reset

### Approvals:

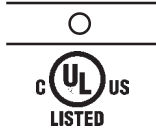

○ Awaiting approval

### User's advantages:

- 3 NO contacts, 250 VAC / 6 A / 1500 VA
- 1 NC contact, 250 VAC / 6 A / 1500 VA
- 1 transistor output for PLC monitoring
- Supply voltages: 24 V AC/DC, 48 - 240 VAC ± 10%
- Terminal X2 current limited (max. 150 mA)
- 22,5 mm housing with or without detachable terminals
- LED indication of output status for K1 and K2
- Separate 24 VDC output for e.g. PLC monitoring or indication of supply voltage
- AC/DC supply results in protection against wrong polarization
- Connection of external relays
- Design is based on the European Standard, EN 60204-1
- Complies with MD, EMC, LVD (98/37/EC, 92/31/EEC and 73/23/EEC)

➔ **Technical specifications and physical dimensions, see page 44-45**

### Block diagram

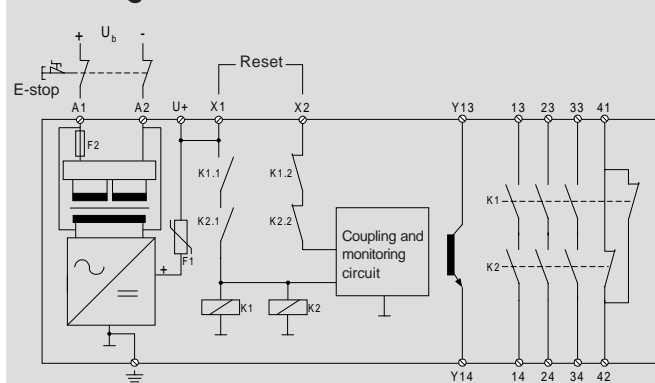

### Front layout

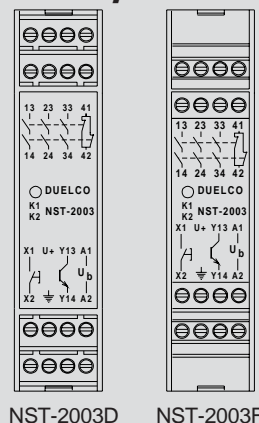

### Terminal description:

- A1(+):** Power supply (+)
- A2(-):** Power supply (-)
- X1\*:** Reset, output (+24V)
- X2\*:** Reset, input
- 13-14,** NO safety output
- 23-24,** NO safety output
- 33-34:** NO safety output
- 41-42:** NC signal output
- Y13-Y14:** Transistor output
- U+:** +24 VDC output
- ⊥:** Earth

\* Used for normal and automatic reset

### Order information

Article name	Article no.	
NST-2003D / 24 V AC/DC	42042306	* 48-240 V AC version can also be supplied with the following DC-voltage range: 55-300 V DC.
NST-2003F / 24 V AC/DC	42042307	
NST-2003D / 48-240 V AC*	42042308	
NST-2003F / 48-240 V AC*	42042309	

**Note:** D = detachable terminals  
F = fixed terminals

## Operation description and connection examples

The power supply is connected to the terminals A1(+) and A2(-). When not activated, the relay's NO contacts 13-14, 23-24, and 33-34 are open, the NC contact 41-42 is closed and the transistor output Y13-Y14 is non-conducting (OFF). If the emergency stop is deactivated, and the monitoring circuit detects that the relay function is correct, the relay can be started by activating a reset contact between the terminals X1 and X2. This switches on the NO contacts 13-14, 23-24 and 33-34 and the NC contact 41-42 will open. The LED for the relay illuminates and the transistor output Y13-Y14 is conductive/activated.

If the emergency stop is activated, the relays K1 and K2 will be deactivated. This opens the current path 13-14, 23-24, 33-34 and 41-42 closes. Y13-Y14 is non-conductive / deactivated again. After resetting of the emergency stop, the NST-2003 will be ready for activation again, provided that the monitoring circuit detects that the relay is functioning correctly. The terminal output U+ can be used to supply the transistor output Y13-Y14 by PLC monitoring.

**N.B.** Automatic reset can be provided connecting the terminals X1 / X2 permanently.

### 1 1-channel operation

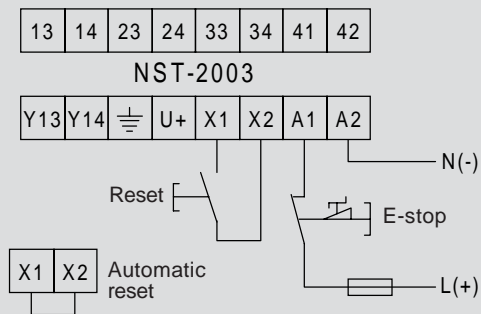

### 2 2-channel operation

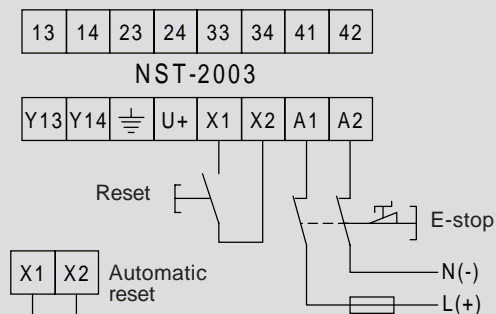

### 3 Connection of external relays (1-channel operation)

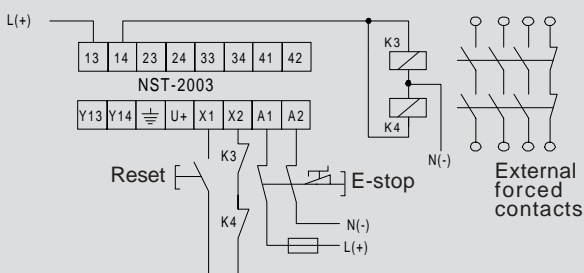

### 4 Connection of external relays (2-channel operation)

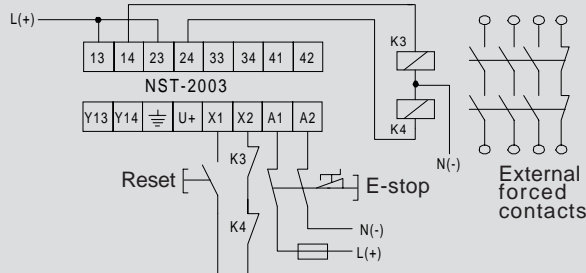

### 5 Monitoring of reset and external contacts

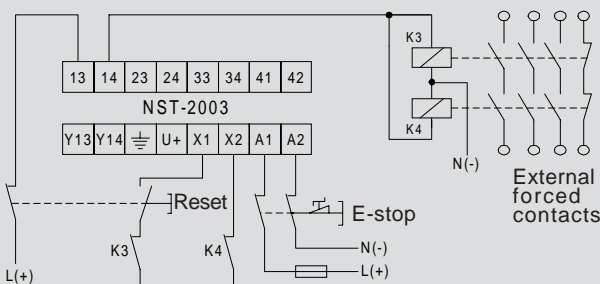

### 6 NST-2003 used as an extension module (1-channel operation)

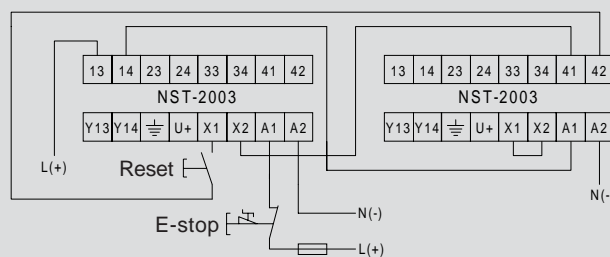

### 7 NST-2003 connected to EU-3 (2-channel operation)

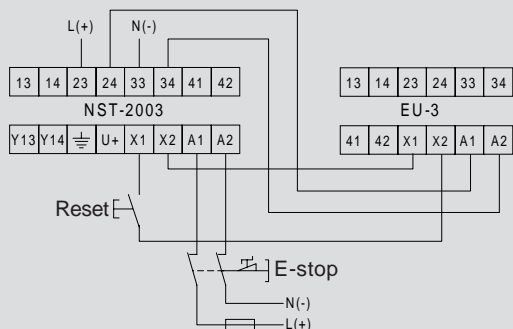

### 8 NST-2003 connected to a PLC and with supply voltage indication

