

NST-9

CE Approved:
MD, EMC, LVD

Category 3/4, EN 954-1

(Estimated category by 2-channel operation)

- 4 input alternatives
- 2 NO safety outputs + 1 NC signal output
- 2 NO time delayed outputs (0 - 6 sec.)
- 3 transistor outputs for PLC-monitoring
- Status indication with LEDs
- Possibility for delayed coupling (0 - 16 sec.)
- Detachable terminals

Function:

Universal usable emergency stop relay, that among other things is suitable for operation with a PLC & CNC / Servo mechanism, contact mat/-list, light curtains and for door monitoring.

Technical facilities regarding safety requirements:

- Forced contacts
- Doubling of output contacts
- Internal / external redundancy (for two pole E-stop)
- Monitored reset

User's advantages:

- 4 NO safety outputs, of which 2 outputs can be delayed 0 - 6 sec.
- 1 NC signal output
- Contact load: 6 A (delayed safety contacts 4 A)
- 1-channel and 2-channel operation
- Manual / automatic / monitored reset
- Output with current limitation for use with a contact mat (max. 60 mA)
- Possibility for delayed coupling of the relay (0 - 16 sec.)
- Supply voltage: 24 VDC, 110 - 240 VAC ± 10%
- 45 mm housing with detachable terminals
- DIN rail mounting
- LED indication of supply + wire- /output condition for K1, K2 and K3/K4
- Design is based on the European Standard, EN 60204-1
- Complies with MD, EMC, LVD (98/37/EC, 92/31/EEC and 73/23/EEC)

Approvals:



● Approved UL-Rating: Pilot Duty, B300; R300

Status table, LEDs

LED U _b	LED K1	LED K2	LED K3/K4	Interpretation / Possible fault causes
Green				Main supply is OK
Flashing				Main supply is too low or I+ has been short circuited Note! U _b is also flashing when the contact mat is activated
OFF				No main supply
	OFF	OFF		Emergency stop contact is active Error on input terminals T10, T11, T12 and/or T13 Error on terminal U+ or I+ Short circuit between T10, T12 and T11 or U+ (I+)
	Yellow	OFF		Error on emergency stop contact to T12, T10 or T13 Short circuit between T12 and T13 or T10 and T12 Error on line to T12, T13 or T10
	OFF	Yellow		Error on emergency stop contact to T11 Short circuit between T11 and T10 Error on line to T11
	Yellow	Yellow		Power on all inputs and all lines OK
	Green	Green		Relay K1 and K2 are active
	Green	Yellow		K2 has not been activated, when reset was done Error - too low main voltage or K2 welded
	Yellow	Green		K1 has not been activated, when reset was done Error - too low main voltage or K1 welded
	Green	OFF		Error on terminal T12, T13 or T10 from active state
	OFF	Green		Error on terminal T11 from active state
			Green	Delay time relay K3 / K4 is activated
			OFF	Delay time relay K3 / K4 is deactivated
	Green	Green	OFF	Internal failure on delay time relays K3/K4

Block diagram:

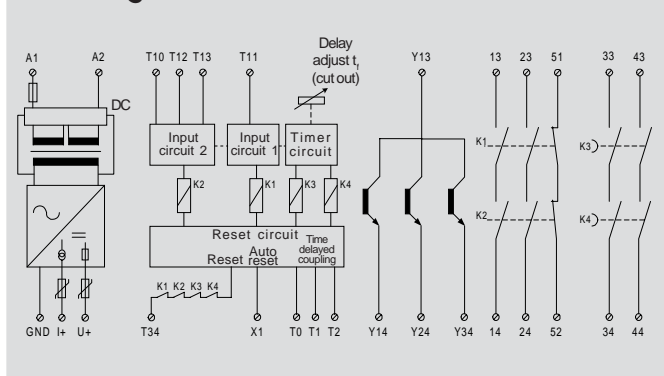

Front layout:

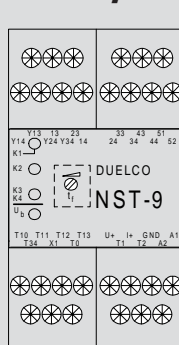

Terminal description:

- A1 / A2: Power supply (+) / Power supply (-)
- X1: Control input (reset)
- T34: 24VDC input (reset)
- Y13: DC-input for Y14, Y24 og Y34
- Y14, Y24 and Y34: NPN-transistor status outputs
- 13-14, 23-24: NO output contacts
- 33-34, 43-44: Delayed NO output contacts
- 51-52: NC signal contact
- T10, T11, T12 and T13: E-stop inputs
- T0, T1 og T2: Programming of the reset time delay
- U+ / GND: +24VDC output / earth
- I+: Current limited output (60 mA)

Order information

Article name	Article no.
NST-9, 24 V DC	42091249
NST-9, 110-240 V AC	42092659

➔ Technical specifications and physical dimensions, see page 44-45

Operation description and connection examples

The power supply is applied across the terminals A1(+) - A2(-). Assuming no internal faults are detected, all wiring is correct and the emergency stop button is deactivated, the power supply LED U_b will illuminate green and the LEDs K1 to K2 will illuminate yellow. The yellow lights give status about the wiring and the emergency stop button on the input. A flashing light from the LED for U_b indicates that the supply voltage is too low (see LED status table)! When the input condition is ready the transistor output Y13 - Y14 is active.

By activation of the reset button connected to $U+$, T34 and possibly X1, the NO safety contacts 13-14, 23-24, 33-34, 43-44 will close and the NC contact 51-52 will open. At the same time the LED's K1, K2, K3 / K4 will illuminate green. The transistor outputs Y13 - Y24 and Y13 - Y34 will be active.

Activation of the emergency stop button will deactivate the relay. The NO safety contacts 13 - 14 and 23 - 24 will open, the NC contact

51-52 will close and the LEDs for K1 and K2 will be extinguished. The transistor outputs Y13 - Y14 and Y13 - Y24 will deactivate. After a delay, controlled by the adjustment of the potentiometer t_1 , (Hidden under the front plate) the NO 33-34 and 43-44 safety contacts will open and the LEDs for K3 and K4 will be turned off. The transistor output Y13 - Y34 will deactivate.

Just 200 ms after the safety contacts for K3 and K4 have opened again and the emergency stop button is deactivated, a reactivation of the relay is possible.

Provided that the LEDs for K1, K2, K3 / K4 illuminate in a different colour or switch off, an error in the current circuit or a defect emergency stop can have occurred (only the LED for the faultless channel will illuminate yellow - see LED status table).

