

# Duelco Safety Technique



## Emergency stop relay NST-2004

- Easy installation and maintenance
- Reliable and a high safety level
- Status-/fault indication via LEDs
- 3 NO safety outputs
- 1 transistor or 1 NC status output
- Short circuit monitoring
- Suitable for light curtain applications

### APPROVALS

Authority	Underwriters Laboratories
NST-2004	○



○ Approval expected

SAFETY CATEGORY, EN 954-1: 4



What can the new Duelco emergency stop relay NST-2004 offer you?

- **Simplicity**  
Fast and easy installation via user friendly connection examples
- **Designed for control of safety light curtains**
- **Easy maintenance -> Time saving**  
Detachable terminals make installation easier, reduces time for replacement and reduces the risk of incorrect wiring. The internal PTC fuse regenerates itself if an error should occur, which result in short breakdowns
- **Cat. 4 safety level with 3 NO duplicated output contacts**
- **Status-/fault indication**  
LEDs for indication of the status of the internal relays, the outputs and the supply. The LED signalling can reduce trouble shooting time.

With the new design and a simple and safe layout, the Duelco NST-2004 is the right choice!

### Technical facilities regarding safety requirements:

- ☑ Forced contacts
- ☑ Doubling of output contacts
- ☑ Internal / external redundancy (for two-pole E-stop)
- ☑ Manual, automatic or manual monitored reset (dip switch selection)

### User's advantages:

- ☑ Safety category 4 or lower cf. EN 954-1
- ☑ STOP category 0
- ☑ 3 NO contacts, AC1: 230 V AC / 6A ; DC1: 24V / 6A
- ☑ 1 transistor output 5-30 VDC (max. 20 mA) or 1 NC contact 24VDC/2A (slide switch selection)
- ☑ 2-channel operation with / without short circuit protection
- ☑ Connection to light curtains
- ☑ 1-channel operation
- ☑ By 2-channel operation with manual monitored reset the coupling current in the E-Stop circuit is < 70 mA
- ☑ By 2-channel operation with automatic/manual reset the coupling current in the E-Stop circuit is < 420 mA
- ☑ Voltage versions: 24VDC, 24VAC, 48VAC, 115VAC and 230VAC
- ☑ No requirements concerning simultaneity between CH1 and CH2
- ☑ 22,5 mm slimline housing with fixed or detachable terminals
- ☑ LED indication of supply + output status of K1, K2
- ☑ Complies with MD, EMC, LVD (98/37/EC, 89/336/EEC & 93/68/EEC)

### Front layout

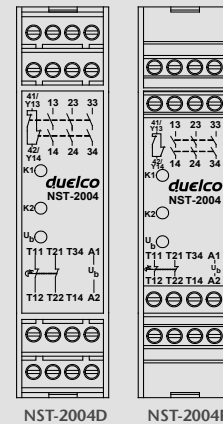

### Block diagram

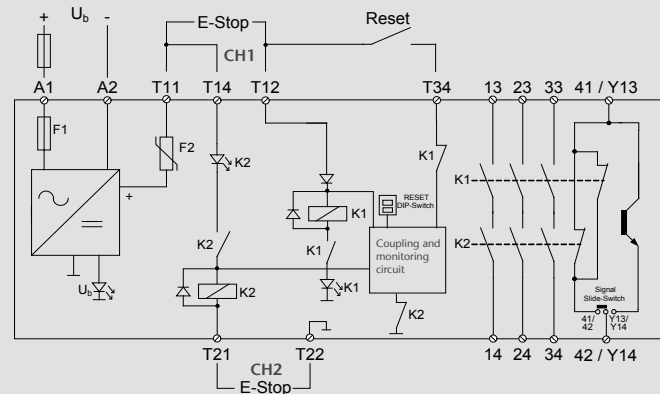

### Distributors:

Australia: Sentec P/L, +61 738481144 • Austria: tvs, +43 512 304161 • England: OEM Automatic Ltd, +44 1162849900 • Estonia: Vitech Oü, +37 256958128 • Finland: OEM Automatic OY, +358 24120400 • France: AE&T, +33 559060600 • Iceland: Samey HF, +354 5105200 • New Zealand: Electropar Limited, +64 92742000 • Norway: Autic System AS, +47 33300950 • Poland: CONTEC Sp. Z.o.o., +48 618108350 • Spain: Star Automation S.L., +34 938403217 • Sweden: Automation System AB, +46 41369220 • Switzerland: Bachofen AG, +41 19441111 • Taiwan: Chinguan Enterprise Co. Ltd, +886 422336838 • The Netherlands (including Belgium and Luxemburg): forTop, +31 365219120 • Turkey: SIMEKS, +90 2122386963 • USA: EMS Controls Inc, +001 9416379669

## Operation description

The power supply is connected to the terminals A1(+) and A2(-), the LED  $U_b$  illuminates. When not activated, the relay's NO contacts 13-14, 23-24 and 33-34 are open and the NC contact 41-42 / transistor output Y13-Y14 is closed / non conductive. If the emergency stop is deactivated, and the monitoring circuit detects that the relay function is correct, the relay can be started by activating a reset contact between the terminals T12 and T34 (automatic, manual or manual monitored reset). This switches on the

NO contacts 13-14, 23-24, 33-34, the NC signal contact 41-42 opens or the transistor output Y13-Y14 is conductive. The LEDs K1 and K2 illuminates. If the emergency stop button is activated, the relays K1 and K2 will deactivate. The NO safety contacts 13-14, 23-24, 33-34 opens and the NC signalling contact 41-42 closes / Y13-Y14 is non-conductive. A short circuit between the two emergency stop contacts will deactivate the NST-2004 via the internal PTC-fuse (i.e. the emergency stop relay can be reset again when the short circuit/error is removed!).

## Dimensions

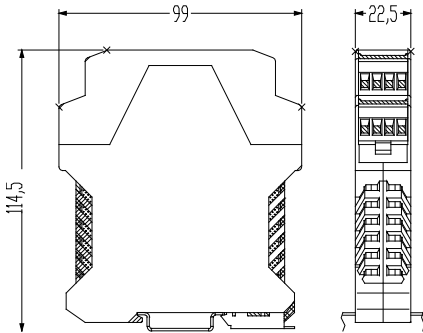

## Order information

NST-2004	Article no.
24 VDC, fixed terminals (F)	42010204
24 VDC, detachable terminals (D)	42011204
24 VAC, fixed terminals (F)	42011301
24 VAC, detachable terminals (D)	42011401
48 VAC, fixed terminals (F)	42012401
48 VAC, detachable terminals (D)	42013401
115 VAC, fixed terminals (F)	42011501
115 VAC, detachable terminals (D)	42011601
230 VAC, fixed terminals (F)	42012301
230 VAC, detachable terminals (D)	42013301

## Status table

LED $U_b$	LED K1	LED K2	Interpretation / Possible fault (depends on which connection example is being used)
ON			Supply OK
OFF			Supply not connected or missing / bad connection / internal blown fuse
	ON	ON	Relay K1 and K2 activated / emergency stop OK
	OFF	OFF	Relay K1 and K2 are deactivated; error between the two emergency stop inputs
	ON	OFF	K1 activated and K2 deactivated; error on emergency stop at T14, T21, T22. K1 may be welded / defect
	OFF	ON	K1 deactivated and K2 activated; error on emergency stop at T11, T12. K2 may be welded / defect

## Technical data NST-2004

Supply voltage (NB! From one common supply):	A: 24 VDC, B: 24 VAC, C: 48 VAC, D: 115 VAC, E: 230 VAC
Maintenance voltage:	A: >12 VDC, B: >15 VAC, C: >30 VAC, D: >70 VAC, E: >150 VAC
Supply tolerance:	± 10%
Fuse, Power supply:	T315 mA
NO / NC:	F 6 A / F 2 A
Max. ripple, DC:	A: ± 1V
Max. inrush current, supply DC:	~ 3A < 3 ms.
Frequency:	47-52/57-62Hz
Consumption:	DC: ~ 1,2 VA, AC: ~ 3,5 VA
# NO / NC / CO:	3 / 1 / 0
Contact material:	AgSnO <sub>2</sub> 0,5μ Au
Max. contact voltage:	250 VAC / 24 VDC
Max. contact current:	6A AC / 6A DC; Cosφ=1; @20°C
Max. effect, 13-14, 23-24, 33-34:	1380 VA
Max. inrush current, output contacts:	20 A < 100 ms.
Min. cut-in time by nominal voltage, DC:	<120 ms. (manual reset); <120 ms. (auto. reset); <40 ms (manual monitored reset)
Min. cut-in time by nominal voltage, AC:	<100 ms. (manual reset); <375 ms. (auto. reset); <40 ms (manual monitored reset)
Cut-out time by activation of emergency stop:	<20 ms.
Cut-out time by power failure:	<100 ms.
Reactivation time:	<500 ms.
Transistor output:	Y13-Y14: 5-30V / Max. 20 mA
Terminal voltage:	T11/T12, T14 = 24VDC; T21/T22 = 0VDC
Terminal current at DC, Static/Peak, (manual/automatic reset/manual monitored reset):	A1-A2: <100mA (<100mA)/<2500mA (-); T11: <100mA (<100mA)/<420mA (-); T12: <45mA (<45mA)/<420mA (<75mA); T14: <60mA (<60mA)/(-); T21: <60mA (<60mA)/<420mA (<70mA); T34: (-)/<75mA (<75mA)
Measured by 26.4 VDC supply voltage	
Max. overall cable resistance, input terminals:	A: ~ 60 Ω / B, C, D, E: ~ 100 Ω
Status indication:	3 x LED
Enclosure, Housing / Terminals:	IP40 / IP20
Enclosure material:	Polyamide PA 6.6
Temperature, Operation / Stock:	-10 - 50°C / -30 - 70 °C
Max. crosssection of conductor, Solid thread / Multiwire with ferrule:	1 x 2,5 mm <sup>2</sup> / 1 x 2,5 mm <sup>2</sup>
Weight AC/DC:	~ 250 g / ~ 200 g
Mounting, DIN-rail / Mounting bracket:	DIN EN 50022-35 / M4 (2 pieces.)
Terminal tightening torque:	<1 Nm
Dimensions, WxHxD (mm):	22,5 x 99 x 114,5
Mechanical lifetime (number of activations):	>10 millions
Insulation class:	4kV/2, VDE 0110-1 / -2
EMC requirements:	EN 61000-6-3 EN 61000-6-2

Duelco a/s accepts no responsibility for possible errors and deficiencies in brochures, catalogues and other printed material.

Duelco a/s reserves the right to alter its products without prior notice. This also applies to products already on order provided that such alterations can be made without subsequent changes being necessary in specifications already agreed. Duelco a/s guarantees correct function as well as fulfilment of the safety requirements only when connections are made in accordance with instructions.

## Connection examples

### 1. 1-channel operation

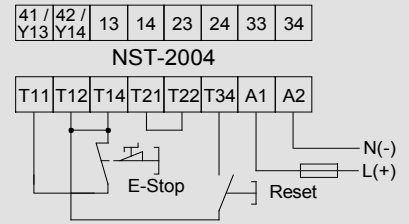

### 2. 2-channel operation with short circuit protection

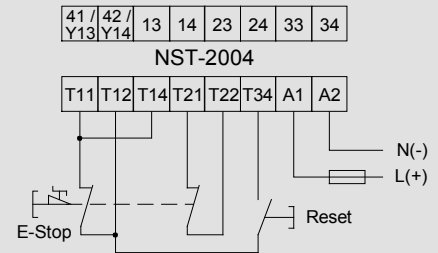

### 3. 2-channel operation with light curtain

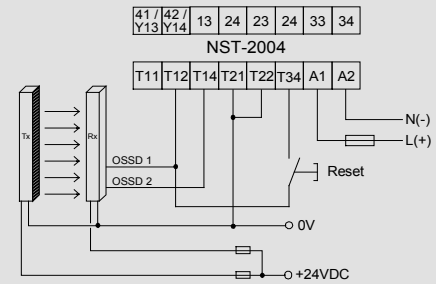

### 4. 2-channel operation without short circuit protection

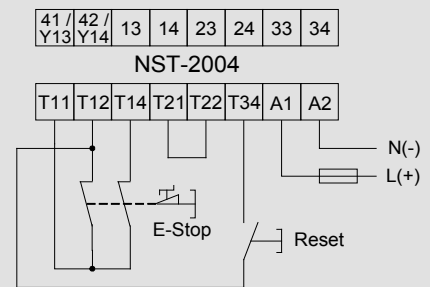

### 5. Connection of external relays

