

Duelco Safety Technique



Extension module EU-2001

- 22,5 mm slimline relay
- Easy installation and maintenance
- Reliable
- Status-/fault indication via LEDs
- 4 NO safety outputs
- With or without time delay
- Transistor output
- Contact load: 6A AC / 6A DC

APPROVALS

Autoritet	Underwriters Laboratories	
EU-2001	●	

● Approved

SAFETY CATEGORY, EN 954-1: 4

What can the new Duelco extension contact block EU-2001 offer you?

- **Simplicity**
Fast and easy installation via user friendly connection examples
- **Designed for the increasing of the number of safety contacts**
- **Easy maintenance -> Time saving**
Detachable terminals make installation easier, reduces time for replacement and reduces the risk of incorrect wiring.
- **Cat. 4 safety level or lower**
- **Status-/fault indication**
LEDs for indication of the status of the internal relays and the supply. The LED signalling can reduce trouble shooting time.

With the new design and a simple and safe layout, the Duelco EU-2001 is the right choice!

Technical facilities regarding safety requirements:

- ✓ Forced contacts
- ✓ Doubling of output contacts
- ✓ Feedback control loop connection X1-X2
- ✓ 4 NO safety contacts

User's advantages:

- ✓ Safety category 4 or lower cf. EN 954-1
- ✓ Optional time delay between 0,5s, 1,0s, 2,0s, 4,0s and 6,0s
- ✓ Duplication from input to output via forced and monitored circuits
- ✓ 4 NO safety contacts with or without delay coupling 230VAC / 6A / 1380VA
- ✓ 1 transistor output Y14 for PLC monitoring
- ✓ EU-2001S especially suitable for servo applications
- ✓ Can operate with all NST- and HR-relays
- ✓ Supply voltage: 24 V DC +/- 10%
- ✓ 22,5 mm slimline housing with fixed or detachable terminals
- ✓ LED indication of the supply and output status of K1 and K2
- ✓ Complies with MD, EMC, LVD (98/37/EC, 89/336/EEC & 93/68/EEC)

Front layout

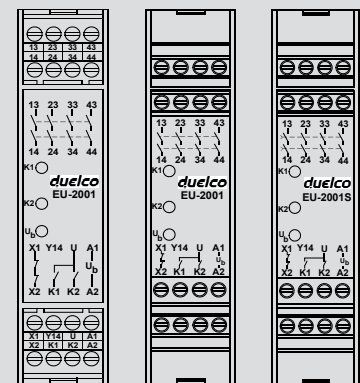

EU-2001D

EU-2001F

EU-2001S

Block diagram

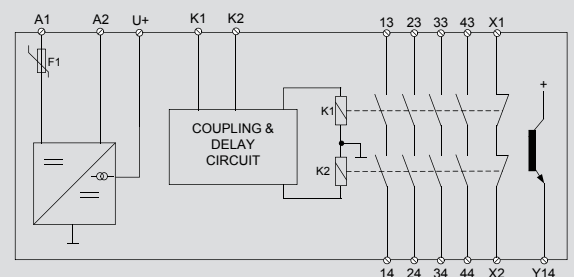

Distributors:

Australia: Sentec P/L, +61 738481144 • Austria: tvs, +43 512 304161 • England: OEM Automatic Ltd, +44 1162849900 • Estonia: Vitech Oü, +37 256958128 • Finland: OEM Automatic OY, +358 24120400 • France: AE&T, +33 559060600 • Iceland: Samey HF, +354 5105200 • New Zealand: Electropar Limited, +64 92742000 • Norway: Autic System AS, +47 33300950 • Poland: CONTEC Sp. z o.o., +48 618108350 • Spain: Star Automation S.L., +34 938403217 • Sweden: Automation System AB, +46 41369220 • Switzerland: Bachofen AG, +41 19441111 • Taiwan: Chinguan Enterprise Co. Ltd, +886 422336838 • The Netherlands (including Belgium and Luxemburg): forTop, +31 365219120 • Turkey: SIMEKS, +90 2122386963 • USA: EMS Controls Inc, +001 9416379669

Operation description

The power supply is connected to the terminals A1(+) and A2(-). Further the return coupling X1-X2 is connected to the EU-2001 on the feedback terminals of the emergency stop relay. In this way the extension block is incorporated in the safety circuit. The activation of the extension contact block, takes place according to the starting of the applied type of safety relay. The extension contact block can be operated either as a 1-channel or 2-channel relay. In regards to EU-2001S, the output contacts are not deactivated until after the specified time period

(0,5s, 1,0s, 2,0s, 4,0s, 6,0s) after the deactivation/disconnection of the monitoring safety relay. The transistor output follows the output of the EU-2001. The decision to select 1- or 2-channel operation in connection with the extension block, depends on the level of safety which the system must provide. The extension block EU-2001 **must** be connected to an emergency stop relay, as the extension block does not in itself fulfil any safety requirements!

Dimensions

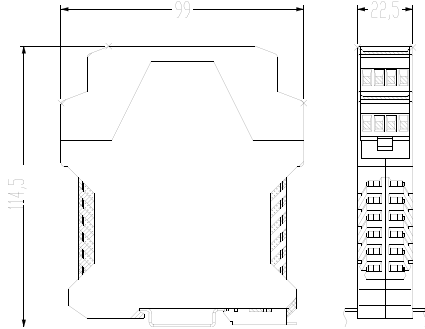

Status table

LED Ub	LED K1	LED K2	Interpretation / Possible fault (depends on which connection example is being used)
ON			Supply OK
OFF			Supply not connected or missing / bad connection / internal blown fuse
	ON	ON	Relay K1 and K2 activated
	OFF	OFF	Relay K1 and K2 are deactivated
	ON	OFF	K1 activated and K2 deactivated; error in connection. K1 may be welded / defect
	OFF	ON	K1 deactivated and K2 activated; error in connection. K2 may be welded / defect

Technical data EU-2001	EU-2001S, 7,0s.	EU-2001
Supply voltage (NB! From one common supply):	24 VDC	24 VDC
Maintenance voltage:	>5 VDC	>5 VDC
Supply tolerance:	± 10%	± 10%
Fuse, Power supply: NO / NC:	T315 mA F 6 A	T315 mA F 6 A
Max. ripple, DC:	± 1V	± 1V
Max. inrush current, A1-A2:	~ 1,75 A < 200 ms.	~ 100 mA
Frequency:	47-52/57-62Hz	47-52/57-62Hz
Consumption:	~ 1,5 VA	~ 0,25 VA
Min. cut-in time:	<30 ms.	<20 ms.
Cut-out time by activation of emergency stop:	< app. 0.5s. / 1s. / 2s. / 4s. / 6s. / 7s.	<20 ms.
Cut-out time by power failure:	< app. 0.5s. / 1s. / 2s. / 4s. / 6s. / 7s.	<20 ms.
Terminal voltage U+, K1 and K2:	24 VDC	24 VDC
Terminal current, Static/Peak, U+ K1 K2	~ 100 mA / 1,75 A < 200 ms. ~ 50 mA / 1,0 A < 200 ms. ~ 50 mA / 1,0 A < 200 ms.	~ 100 mA ~ 50 mA ~ 50 mA
Measured by 26.4 VDC supply voltage		
Max. overall cable resistance, input terminals:	~ 33 Ω	~ 33 Ω
Status indication:	3 x LED	3 x LED
Transistor output (max. 20 mA)	1	1
# NO / NC:	4 / 0	4 / 0
Contact material:	A Alloy +0,2-0,4 μm Au	A Alloy +0,2-0,4 μm Au
Max. contact voltage:	250 VAC / 24 VDC	250 VAC / 24 VDC
Max. contact current:	6A AC / 6A DC; Cosφ=1; @20°C	6A AC / 6A DC; Cosφ=1; @20°C
Max. effect, 13-14, 23-24, 33-34:	1500 VA	1500 VA
Max. inrush current, output contacts:	30 A < 20 ms.	30 A < 20 ms.
Mechanical lifetime (number of activations):	>10 millions	>10 millions
Enclosure, Housing / Terminals:	IP40 / IP20	IP40 / IP20
Enclosure material:	Polyamide PA 6.6	Polyamide PA 6.6
Temperature, Operation / Stock:	0 - 50°C / -30 - 70 °C	0 - 50°C / -30 - 70 °C
Max. crosssection of conductor, Solid thread / Multiwire with ferrule:	1 x 2,5 mm ² / 1 x 2,5 mm ²	1 x 2,5 mm ² / 1 x 2,5 mm ²
Weight DC:	~ 200 g	~ 200 g
Mounting, DIN-rail / Mounting bracket:	DIN EN 50022-35 / M4 (2 pcs.)	DIN EN 50022-35 / M4 (2 pcs.)
Terminal tightening torque:	<1 Nm	<1 Nm
Dimensions, WxHxD (mm):	22,5 x 99 x 114,5	22,5 x 99 x 114,5
Insulation class:	4kV/2, VDE 0110-1 / -2	4kV/2, VDE 0110-1 / -2
EMC requirements:	EN 61000-6-3 EN 61000-6-2	EN 61000-6-3 EN 61000-6-2

Connection examples

1. 1-channel operation connected to NST-2004

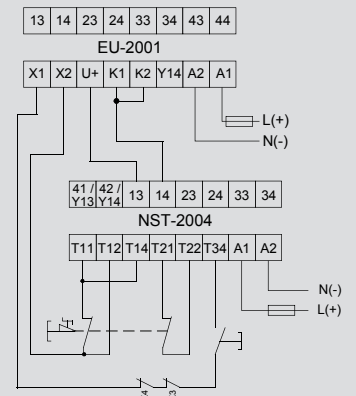

2. 2-channel operation connected to NST-2004

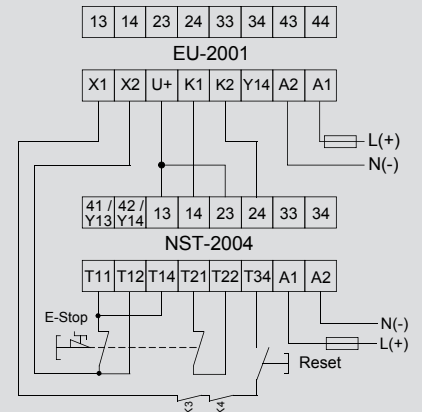

3. EU-2001 connected to HR-2001/TST-2

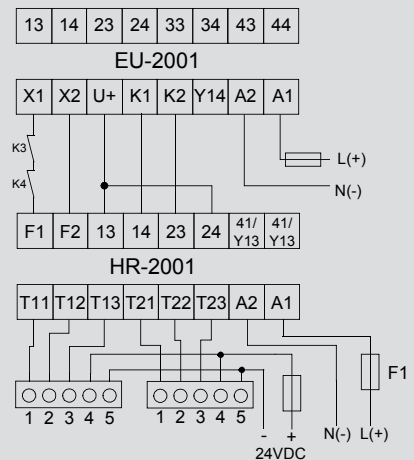

4. Series connection of several extension blocks

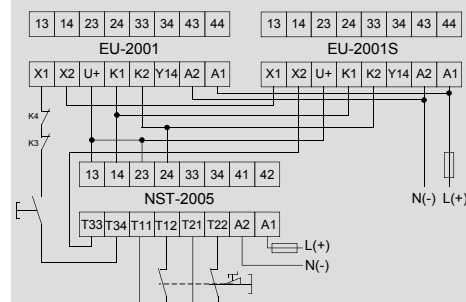

Duelco A/S accepts no responsibility for possible errors and deficiencies in brochures, catalogues and other printed material.

Duelco A/S reserves the right to alter its products without prior notice. This also applies to products already on order provided that such alterations can be made without substantial changes being necessary in specifications already agreed. Duelco A/S guarantees correct function as well as fulfillment of the safety requirements only when connections are made in accordance with instructions.